

Operation Manual

Jitter Meter

KJM 6235

 **KIKUSUI**

Electronic Test
Instruments &
Power Supplies

 **KIKUSUI**

■ About this manual

We recommend that you read this manual thoroughly beforehand to ensure correct operation of the product. Be sure to store the manual in safe place so that you can use it whenever necessary. When transferring the product to other persons, be sure to supply the manual.

All or any parts of this manual may not be reproduced in any forms, without express written permission of Kikusui Electronics Corporation.

The contents of this manual, including the specifications of the instrument, are subject to change without notice.

Kikusui Part No.Z1-000-932 IA000153

Printed in Japan

Safety Precautions

The following safety precautions must be observed to avoid fire hazard, electrical shock, accidents, and other failures. Keep them in mind and make sure that all of them are observed properly. Kikusui assumes no liability against any damages or problems resulting from negligence of the precautions.

■ Users

- This product must be used only by qualified personnel who understand the contents of this operation manual.
- If it is handled by disqualified personnel, personal injury may result. Be sure to handle it under supervision of qualified personnel (those who have electrical knowledge.)

■ Purposes of use

- If the product is to be used for purposes not described in this manual, contact your Kikusui agent in advance.

■ Input power

- Use the product with the specified input power voltage.
- For applying power, use the AC power cable provided. The shape of the plug differs according to the power voltage and areas. Use the cable which is suitable for the line voltage used.

■ Fuse

- With products with a fuse holder on the exterior surface, the fuse can be replaced with a new one. When replacing a fuse, use the one which has appropriate shape, ratings, and specifications.

■ Cover

- There are parts inside the product which may cause physical hazards. Do not remove the external cover. If the cover must be removed, contact your Kikusui agent in advance.

■ Installation

- When installing products be sure to observe "Precautions for Installation" described in this manual.
- To avoid electrical shock, connect the protective ground terminal to electrical ground (safety ground).

- When applying power to the products from a switchboard, be sure work is performed by a qualified and licensed electrician or is conducted under the direction of such a person.
- Be sure to use the AC power cable provided. Consult your Kikusui agent if other cable than included is to be used for some reason.

■ Relocation

- Turn off the power switch and then disconnect all cables when relocating the product.
- Be sure the operation manual be included whenever the product is moved, relocated, or possession is passed to another party.

■ Operations

- Check that the AC input voltage setting and the fuse rating are satisfied and that there is no abnormality on the surface of the AC power cable. Be sure to unplug the AC power cable before checking.
- If any abnormality or failure is detected in the products, stop using it immediately. Unplug the AC power cable. Be careful not to allow the product to be used before it is completely repaired.
- For output wiring or load cables, use connection cables with larger current capacity.
- Do not disassemble or modify the product. If it must be modified, contact your Kikusui agent.

■ Maintenance and checking

- To avoid electrical shock, be absolutely sure to unplug the AC power cable before performing maintenance or checking.
- Do not remove the cover when performing maintenance or checking. If the cover must be removed, contact your Kikusui agent in advance.
- To maintain performance and safe operation of the product, it is recommended that periodic maintenance, checking, cleaning, and calibration be performed.

■ Service

- Internal service is to be done by Kikusui service engineers. If the product must be adjusted or repaired, contact your Kikusui agent.

Safety Symbols

This operation manual and this product use the following safety symbols. Note the meaning of each of the symbols to ensure safe use of the product. (Using symbols depend on the product. Therefore all of symbols may not be used.)

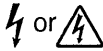

Indicates the presence of 1000V or higher. Never attempt to touch this part when the power switch of the product is turned on.



Indicates the possibility of personal injury or death. Never fail to follow the operating procedure. Do not proceed beyond a WARNING sign until the noted conditions are fully understood and met.



Indicates the existence of damage to the product or connected equipment. Always follow the operating procedure. Do not proceed beyond a CAUTION sign until the indicted conditions are fully understood and met.



Indicates additional information such as operating procedure.



Describes technical terms used in this manual.



Indicates general warning, caution, risk of danger. When this mark is indicated on the product, refer the relevant section of the Operation Manual.

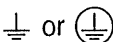

Indicates a grounding (earth) terminal.



Indicates a chassis grounding terminal.

CONTENTS

Safety Precautions	I
Safety Symbols	III
Preface	vi
Chapter 1 SETUP	1-1
1.1 Checking at Unpacking	1-1
1.2 Precautions for Installation	1-2
1.3 Checking Input Power Supply	1-3
1.4 Grounding	1-4
Chapter 2 OPERATION	2-1
2.1 Initial Operation	2-1
2.2 Measuring Jitter	2-2
2.3 Internal self calibration	2-3
2.4 Auto Symmetry	2-4
Chapter 3 GPIB OPERATION	3-1
General	3-1
3.1 Setting the GPIB Switch	3-2
Notes on the GPIB Switch	3-2
3.2 Setting the Delimiter	3-3
3.3 Command and Data Formats	3-4
(1) Command	3-4
(2) Command abbreviation	3-4
(3) SRQ and status byte	3-4
3.4 Panel Switch Setting Command	3-5
3.4.1 Command Syntax Diagram	3-6
3.4.2 Setting Command List	3-7

3.5	Command Which Reads Panel Switch Settings or Measurement Data	3-7	
3.5.1	Command Syntax Diagram	3-8	
3.5.2	Command List	3-8	
Chapter 4	NAME AND FUNCTIONS OF CONTROLS		4-1
4.1	Front Panel	4-1	
4.2	Rear Panel	4-2	
	Fig. 4-1 Front Panel	4-3	
	Fig. 4-2 Rear Panel	4-4	
Chapter 5	MAINTENANCE	5-1	
5.1	Cleaning	5-1	
5.2	Inspection	5-1	
Chapter 6	SPECIFICATIONS	6-1	
	• GPIB Interface (Factory Option)	6-4	
	• GPIB Cable	6-4	

Preface

General description

The Kikusui Jitter Meter KJM6235 model is equipment for measuring the jitter of an output signal (EFM signal) from the optical pickup of a compact disk (CD) player.

The KJM6235 is speed compatible from the standard CD speed to the octuple ($\times 8$) CD speed. It is available for both the CD-ROM drive and the MD drive. The jitter evaluation result is digitally displayed using the standard deviation value.

The KJM6235 Jitter Meter can be used for a variety of applications including the production line and inspection measurement of the DVD players.

Features

- 1) Compatible with four types of drive speeds; standard, double, quadruple, octuple.
- 2) 22T delayed sampling measurement method. The 22T delayed sampling method measures jitter in a period of 22 clock pulses, implementing fixed measurement free of the random signal cycle of 3T to 11T. The 22T delayed sampling method is a patent of SONY Corporation.
- 3) Analog wave detection system achieves high real-time resolution (10 ps at octuple speed) with less quantization error in comparison to the counter method.
- 4) Measured values are displayed after effective value conversion, precisely reflecting the jitter when frequency components are distributed in a wide band.

- 5) Self-calibration increases the measurement accuracy.
- 6) Symmetry adjustment function locks on the center of the input signal from the INPUT terminal.
- 7) Three monitor terminals are provided for the input signal, jitter sampling waveform, and effective value signal.
- 8) GPIB interface is available as a factory option.

1.1 Checking at Unpacking

When you unpack the product, make sure that you have all the parts and that none have been damaged during transportation. If any parts is damaged or missing, contact your Kikusui agent.

The product is provided with the following accessories:

Accessory	Q'ty	Checked
Operation Manual	1	
AC power cable	1	
Fuse: 250V 1A or 250V 0.5A	1	

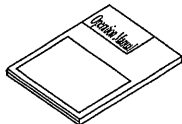

• Operation Manual



• Fuse

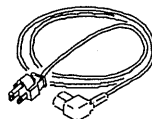

• AC power cable

Fuse: 1 fuse for 250V 1A or 250V 0.5A is set in the fuse holder

CAUTION

- When transporting the product, be sure to use the original packing materials. If they are missing, contact your Kikusui agent.
- When packing the product, remove the AC power cable and all other connection cables.

1.2 Precautions for Installation

The following are the precautions for installation which must be observed.

■ Do not use in explosive atmosphere

To avoid explosion or fire hazard, do not use the product in any areas exposed to inflammable materials such as alcohol or thinner.

■ Do not place the product in high-temperature areas or areas exposed to direct sunlight

Do not place the product near heating element, or heater, or in areas exposed to rapid temperature changes.

Operating temperature range: 5°C to 35°C

■ Do not place the product in humid areas

Do not place the product in any humid areas such as near a water heater, humidifier, or water tap.

Operating humidity range: 85%RH or less

■ Do not place the product in any areas exposed to corrosive gases or sulfuric mist

■ Do not place the product in dusty areas

■ Do not use in any areas which are poorly ventilated

Leave an open space around the product to obtain air flow.

■ Do not place the product in any places where the surface tilted or vibrated

■ Do not use the product in any areas exposed to strong magnetic or electric fields.

1.3 Checking Input Power Supply

- 1 Check that the AC power cable is not connected to the AC connector.
- 2 Remove the voltage selector which is also used for the fuse holder.
- 3 Check the fuse rating in Table 1-2.

Table 1-2

LINE VOLTAGE		FUSE
100	90V~110V	1A
120	104V~126V	AC250V
220	194V~236V	0.5A
240	207V~250V	AC250V

- 4 According to Table 1-2, mate the input voltage range indication to the mating mark ▼ as shown in Fig. 1-2 and insert the fuse holder.

Fig. 1-2

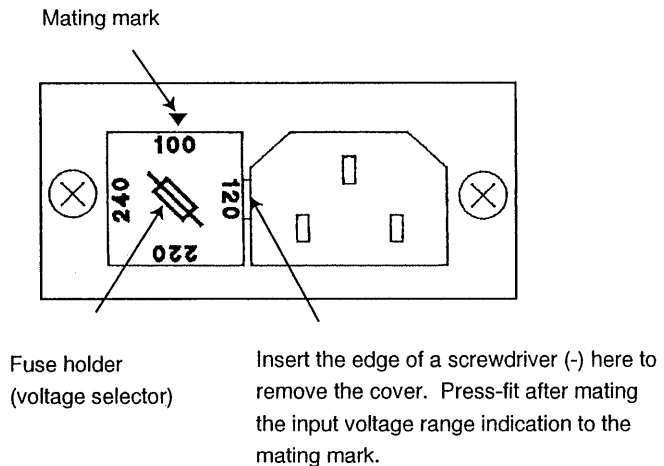

- 5 Check that the voltage matches the rear panel indication before, insert the AC power cable to the AC connector.
Allowable input frequency: 50 Hz or 60 Hz
- 6 Insert the AC power cable plug to the AC power supply selected with the voltage selector.

1.4 Grounding

Connect the ⊕ protective grounding terminal at the rear panel to a ground.

WARNING

- Improper or no grounding may cause electrical shock.
- Connect the ground terminal to electrical ground (safety ground.)

2.1 Initial Operation

- 1 Check that ⑰ 【POWER】 switch is turn off.
- 2 Check that the applied voltage range matches the indication on the rear panel.

CAUTION

· Applying voltages which exceed the value inscribed on the rear panel may damage the product or the fuse inside it.

- 3 Turn on the ⑰ 【POWER】 switch .
 - The KJM6235 starts with the settings used immediately before the power was last turned OFF.
- 4 For stable operation, warm up the KJM6235 for 15 min or more.
- 5 When the above operations are complete, the KJM6235 is ready for jitter measurement.

NOTES

- For measurement with symmetry in the user mode, follow the automatic symmetry operation method. The internal self-calibration will not change the symmetry settings.
- If a message is indicated as shown in Fig. 2-1, the input exceeds the measurement range of the KJM6235.

Fig. 2-1



2.2 Measuring Jitter

- ① Select the input impedance with the ② **【IMPD】** switch.
(1 M Ω , 50 Ω)
- ② Select the CD speed with the ④ **【SPEED(CAL)】** switch. (Read-out speed: $\times 1, \times 2, \times 4, \times 8$)
- ③ Select the user mode or fixed mode with the ⑩ **【SYMMETRY(ADJ)】** switch (USER, FIXED)
- ④ Connect the EFM signal to ① INPUT terminal .

WARNING

- The maximum allowable input voltage is 4V_{peak} (DC+AC peak). If the input voltage exceeds this value, personal injury or KJM6235 damage may occur. Do not use with the input terminal voltage exceeding 4V_{peak} (DC+AC peak).

CAUTION

- When the input signal is connected to the DC-OUT or RF-OUT terminal, the KJM6235 will be damaged.
- ⑤ When the above steps are complete, a measured jitter value is indicated in ⑦ Measured value indication section. When the input is not connected, “---” is indicated.

2.3 Internal self calibration

To keep the measurement accuracy of the KJM6235, perform periodic internal self calibration at $25^{\circ}\text{C} \pm 3^{\circ}\text{C}$

① While pressing ⑥ **【SHIFT】** switch, press ④ **【SPEED (CAL)】** switch to execute internal self-calibration.

The calibration time is about 5 min. “CAL” is indicated in ⑦ Measured value indication section during calibration.

NOTE

- If error indication appears in ⑦ Measured value indication section as shown in (A),(B),(C) of the Fig. 2-2 during calibration, take the following action.
- Since the internal circuitry may not yet be stabilized, reexecute the self-calibration after 15 min. or more. If the same error is still indicated, contact your KIKUSUI agent.

Fig. 2-2

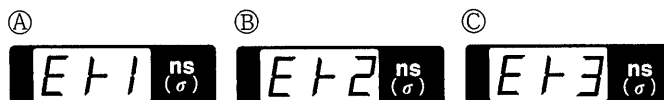

2.4 Auto Symmetry

- ① After the initial operation 2-1, connect the EFM signal as standard to ①INPUT terminal.
- ② Select the user mode with the ⑩ 【SYNMMETRY (ADJ)】 switch.
- ③ While pressing ⑥ 【SHIFT】 switch, press ⑩ 【SYNMMETRY(ADJ)】 switch. When “ADJ” is indicated, a proper symmetry value for the input signal is automatically calculated. It will take about 5 min.
- ④ When the calculation is complete, the system returns to the previous state.

NOTES

- The symmetry value is pre-adjusted to the signal prior to delivery.
- If the symmetry value does not match the signal, the measured jitter value has an error based on the measurement principle of the sampling method.

General

The General Purpose Interface Bus (GPIB) interface is a factory-installed option. It is supplied before delivery or at our service office.

The GPIB is the interface standard for connecting multiple measurement instruments of different makers and with different functions via the interface bus with the unified specifications. The GPIB transfers the signal through the bi-directional bus (bit parallel (8 bits) and byte serial), and transmits data in 3-wire hand-shake mode.

The measurement instruments are connected to each other in parallel on the common signal lines.

The units connected on the bus can have single or multiple functions of talker, listener and controller. Data is transferred from a single unit specified as the talker to one or more units specified as the listener. The unit specified as the controller designates data transmission and reception of the units connected on the bus and controls the GPIB interface. The bus consists of total 16 lines, including 8 data lines, 3 hand-shake lines and 5 bus control lines, and 8 ground lines. The following diagram shows the data lines as DIO1 to DIO8, the hand-shake lines as NDAC, NRFD and DAV, and the bus control lines as ATN, EOI, IFC, SRQ and REN.

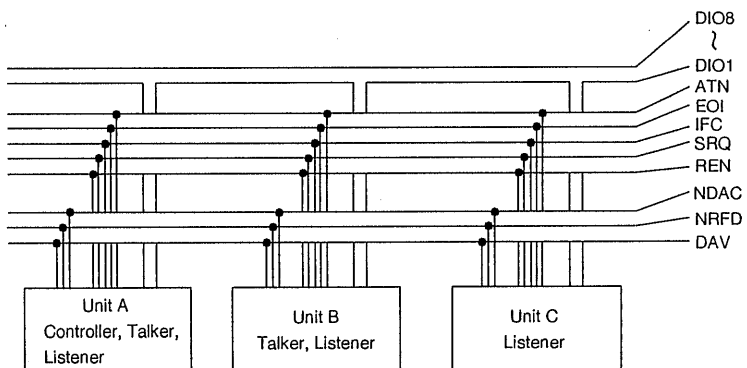

3.1 Setting the GPIB Switch

Be sure to set address before connecting the external computer. The address is set in the five DIP switches (ADRS) of the GPIB switch. Indication of 16 · 4 · 1 stands for 16 8 4 2 1. The address is specified by the sum of values indicated for the DIP switches set to ON (upperside). When all five DIP switches are set to OFF, the address value is 0. For example, to set the address to 6, set the DIP switch indicated as 4 and the DIP switch indicated as · (=2) between 4 and 1 to ON to set $6=4+2$.

Example Address Setting

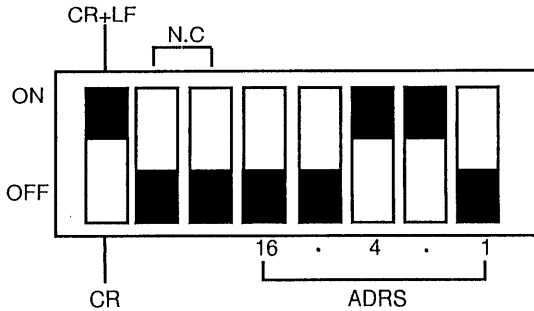

————— NOTE —————

- The address is set to “2” before delivery.

Notes on the GPIB Switch

- The GPIB switch setting is read only once at power on. Thus, any setting change during operation does not modify the address and delimiter. To change the address and/or delimiter, turn off the power, change the setting, and turn on again.
- For other operations, use the GPIB switch based on the ANSI/IEEE Standard 488.1-1987.

3.2 Setting the Delimiter

One of the following five codes can be selected for the data delimiter (end code) in the KJM6235.

- ① EOI
- ② CR
- ③ CR(+EOI)
- ④ CR/LF
- ⑤ CR/LF(+EOI)

EOI : End or Identify
CR : Carriage Return
LF : Line Feed

The delimiter is set with the GPIB switch and “EOI” command.

- For the EOI command, see the panel setting command in Section 3.4.

Delimiter Setting

Delimiter	GPIB Switch	“EOI” Command
EOI	CR or CR+LF	ONLY
CR	CR	OFF
CR (+EOI)	CR	ON
CR/LF	CR+LF	OFF
CR/LF (+EOI)	CR+LF	ON

However, if the EOI signal is received when the delimiter is other than EOI, the delimiter is determined as the command end code at that time.

NOTES

- The delimiter is set to CR/LF(+EOI) with the GPIB switch before delivery.
- When the power is turned on, the EOI command is set to “ON” .
- It is not possible to use only LF for the delimiter.

3.3 Command and Data Formats

When the KJM6235 is controlled by the GPIB, a command is transmitted in the following sequence from the external computer (GPIB controller).

(1) Command

- Command is a character string consisting of ASCII codes.
- Command is composed of the header, argument and separator.

A:

Header

 +

Separator

 +

Argument

 +

Delimiter

or

B:

Header

 +

?

 +

Delimiter

- Header specifies the command type such as “TIME” and “DATA?”

(2) Command abbreviation

- Commands for the KJM6235 can be abbreviated to three characters as can the header and argument.

Example:

“TIME” → “TIM”

“DATA?” → “DAT?”

- The abbreviated headers and arguments are shown in () on the command lists.

(3) SRQ and status byte

- The KJM6235 can transmit SRQ to notify an event generated in the KJM6235 to the external computer.
- Each possible event cause is assigned a status byte bit for its identification. If the KJM6235 transmits SRQ, the corresponding bit will be set to “1”.

Therefore, the computer can read the status byte to recognize the generated event.

- The SRQ transmission cause and the bits corresponding to status bytes are shown below.

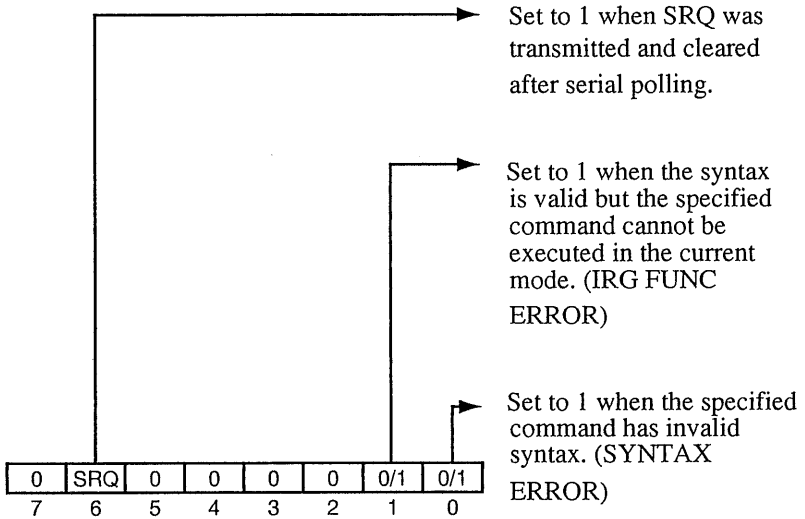

When the power is turned on, all status bytes are set to 0.

————— NOTE —————

- If the status byte is set due to an error, be to perform Device Clear after the serial polling.

3.4 Panel Switch Setting Command

The panel switch settings can be implemented from the external computer.

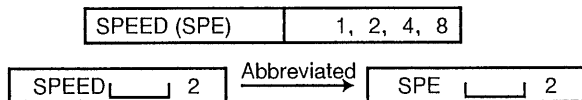

- For example, to set the rotation speed to double speed, the characterstring "SPEED2" is sent to the KJM6235. Then, the KJM6235 interprets the character string and sets and sets the corresponding panel switch value to 2.

3.4.1 Command Syntax Diagram

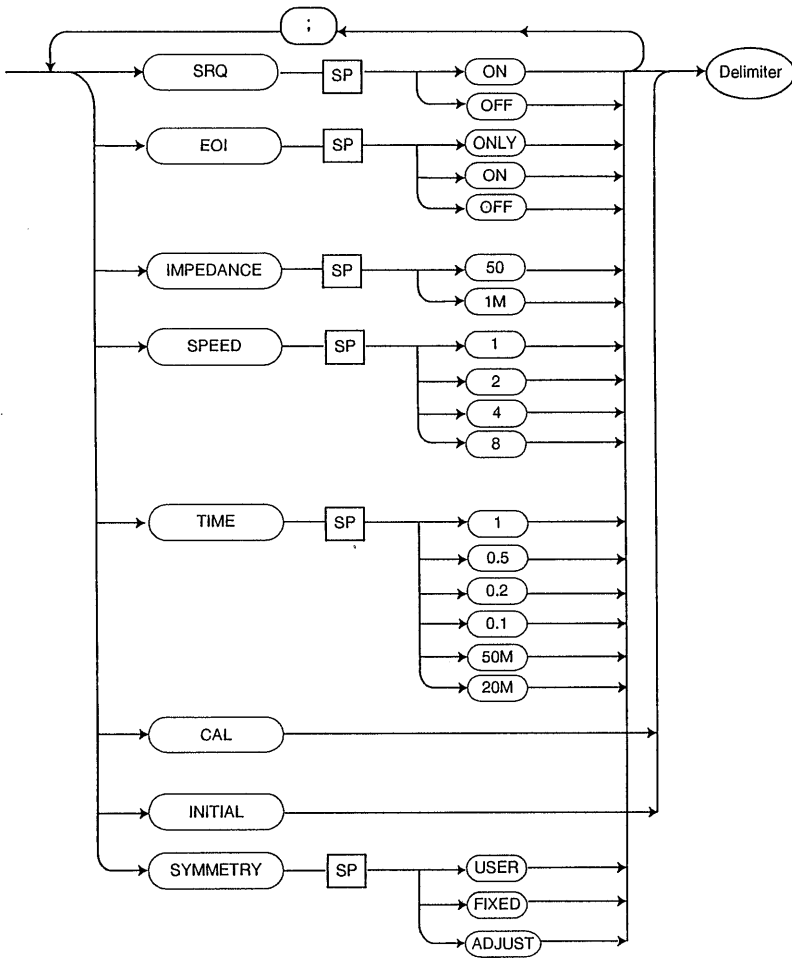

3.4.2 Setting Command List

Header	Argument	Operation
SRQ	ON	Permits SRQ generation.
	OFF	Inhibits SRQ generation.
EOI	ONLY (ONL)	Sets the delimiter at transmission to EOI.
	ON	Permits EOI at transmission.
	OFF	Inhibits EOI at transmission.
IMPEDANCE (IMP)	50, 1M	Sets the input impedance to 50Ω or 1MΩ
SPEED (SPE)	1, 8, DVD	Sets the CD clock speed to 1, 2, 4, or 8 (standard, double, quadruple, octuple).
CAL		Starts the internal self-calibration.
TIME (TIM)	1, 0.5	Sets the effective value conversion time constant output from the GPIB. 1s is indicated.
	0.2, 0.1, 50M, 20M	Sets the effective value conversion time constant output from the GPIB. 0.1s is indicated.
INITIAL (INI)		Resets ③IMPD indication section to 1MΩ, ⑤SPEED indication section to ×1, ⑨TIME CONSTANT indication section to 0.1s, and ⑪SYMMETRY indication section to FIXED.
SYMMETRY (SYM)	USER (USE)	Sets the symmetry to the user mode.
	FIXED (FIX)	Sets the symmetry to the fixed mode.
	ADJUST (ADJ)	Automatically calculates a proper symmetry value for the input signal.

3.5 Command Which Reads Panel Switch Settings or Measurement Data

The measurement data value and panel switch settings are transmitted to the external computer.

DATA ?	Reads out measurement data.
--------	-----------------------------

- For example, to read the measurement data from the KJM6235, the character string "DATA?" is sent to the KJM6235. Then, the KJM6235 interprets the character string and writes measurement data to the transmission buffer. It is necessary to specify the KJM6235 for the talker to read the data.

3.5.1 Command Syntax Diagram

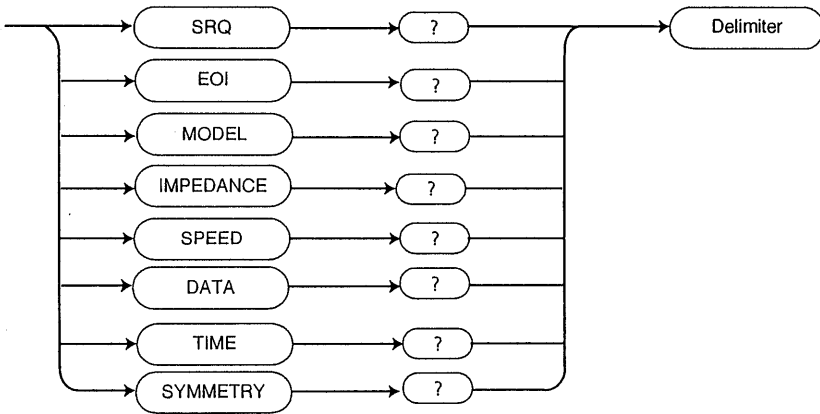

3.5.2 Command List

Header	Operation Header
SRQ?	Returns [ON, OFF].
EOI?	Returns [ONLY, ON, OFF].
MODEL?	Returns the model name [KJM6235].
IMPEDANCE? (IMP?)	Returns input impedance value [50, 1M].
SPEED? (SPE?)	Returns [1, 2, 4, 8].
DATA? (DAT?)	Reads measurement data. (In units of ns) Returns [NO SIGNAL, OVER] when the input signal level is outside the standard or exceeds the full scale, respectively.
TIME? (TIM?)	Returns the time constant [1, 0.5, 0.2, 0.1, 50M, 20M].
SYMMETRY? (SYM?)	Returns the symmetry mode [USER, FIXED].

4.1 Front Panel

See Fig. 4-1.

① INPUT terminal

EFM signal input terminal.

CAUTION

- Do not apply voltage exceeding 4Vp-p, otherwise, KJM6235 will be damaged.

② IMPD switch/③ IMPD indication section

Changeover switch and display of the input terminal input impedance. Select 50Ω or $1M\Omega$.

④ SPEED (CAL) switch/⑤ SPEED indication section

Changeover switch and display of the clock speed. Select $\times 1$, $\times 2$, $\times 4$ or $\times 8$. Press this switch while pressing the SHIFT switch to start the self-calibration.

⑥ SHIFT switch

Used with the CAL or ADJ switch.

⑦ Measured value indication section

Indicates the measured jitter value.

⑧ TIME CONST switch/⑨ TIME CONST indication section

Changeover switch and display of the time constant for jitter amount effective value conversion. Select 0.1s or 1s.

⑩ SYMMETRY (ADJ) switch/⑪ SYMMETRY indication section

Changeover switch and display of the symmetry mode. Select the user mode or fixed mode. Press this switch while pressing the SHIFT switch to start the auto symmetry.

⑫ DC-OUT terminal

Outputs the DC voltage proportional to the displayed measurement value.

⑬ RF-OUT terminal

Input signal monitoring terminal.

CAUTION

- ⑫ and ⑬ are the output terminal. Do not input any signal to avoid damaging the KJM6235.

4.2 Rear Panel

See Fig. 4-2.

⑭ JITTER-OUT terminal

Outputs the sampled jitter before effective value conversion.

⑮ Optional slot

Used to mount the optional GPIB interface.

⑯ Ground terminal

Connect to the external power ground line.

⑰ AC connector

Connect to the AC power cable.

⑱ FUSE

Fuse holder which is also used as the voltage selector. Use the proper fuse for the AC power voltage. Adjust the voltage selector to the input AC power voltage if necessary. For details, see Section 1.3.

⑲ POWER switch

Turns ON/OFF the KJM6235 power supply.

Fig. 4-1 Front Panel

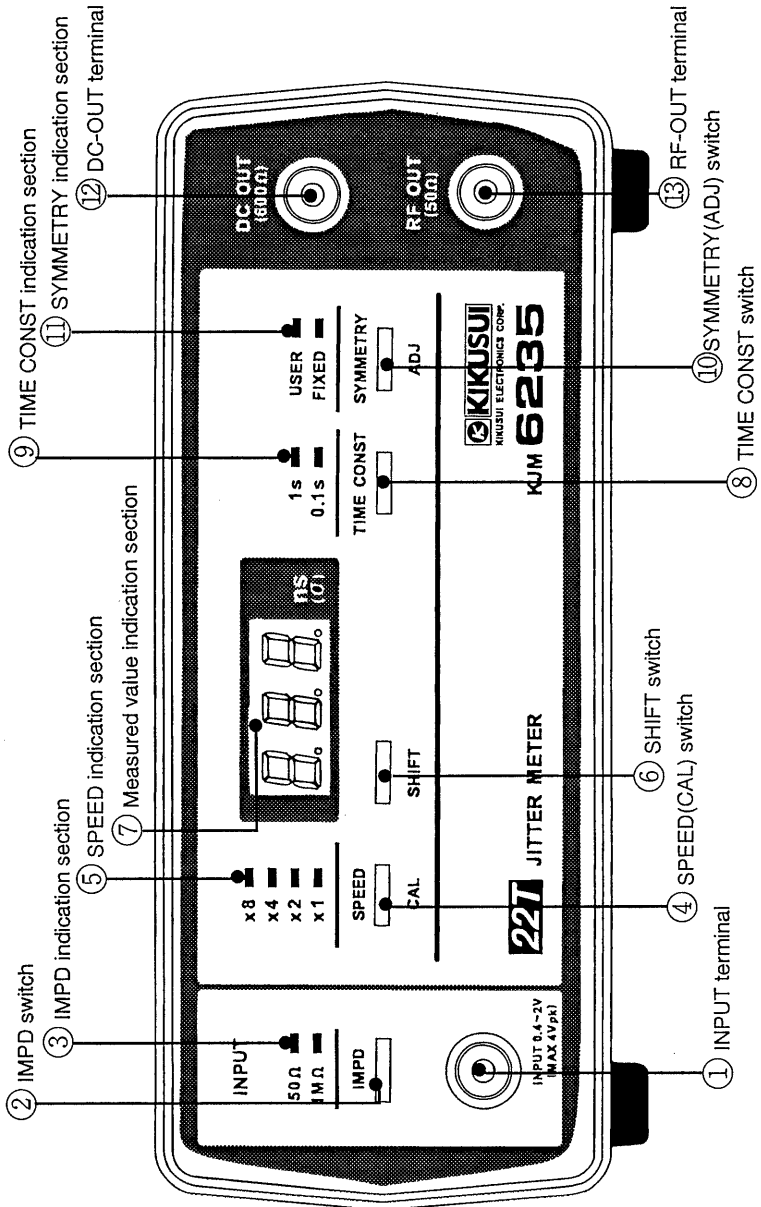
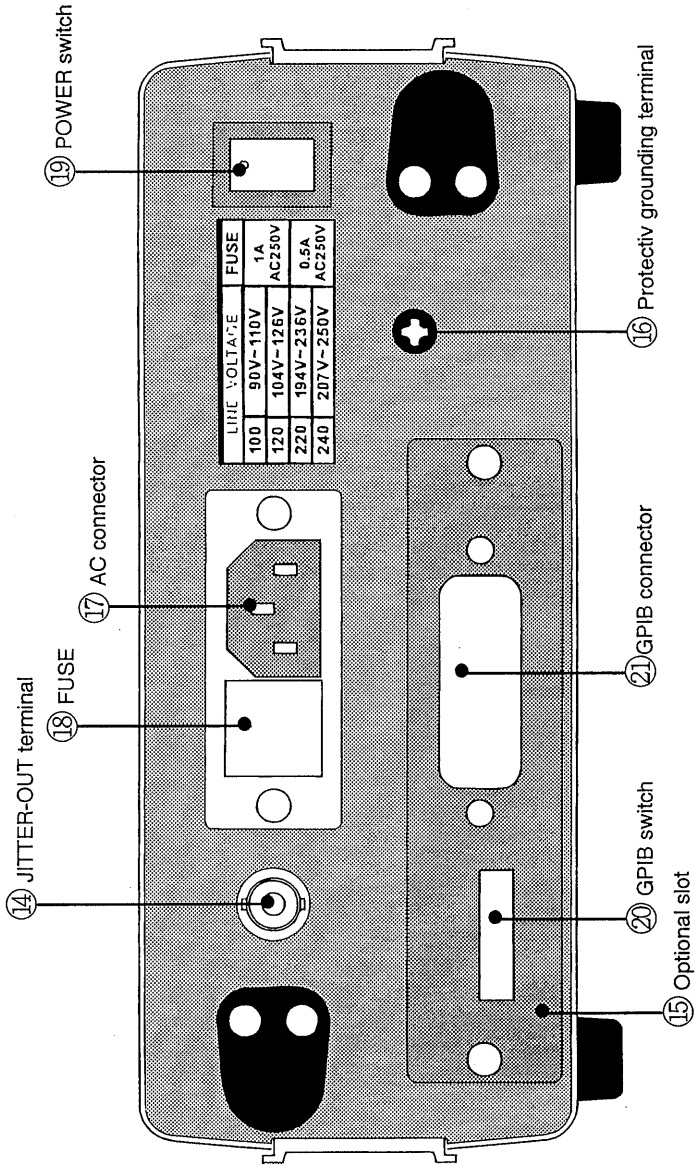

Fig. 4-2 Rear Panel



Periodically maintain and inspect the KJM6235 to preserve the performance.

5.1 Cleaning

To remove dirt from the panel surface or other external surfaces, carefully wipe with soft cloth moistened with diluted neutral detergent.

CAUTION

- Be sure to turn the POWER switch OFF and disconnect the input power cable before cleaning.
- Do not use volatile material including thinner and benzene. It may cause the surface color to change, printed characters to be obliterated or the display surface to be damaged.

5.2 Inspection

Input power cable: Check for broken insulation, loosened plug, cracks, and aging.

WARNING

- Broken insulation may cause electric shock. Immediately disconnect the cable if any break is found.

For accessory purchase, contact your kikusui agent.

The following electrical performance specifications are guaranteed at 5°C to 35°C after the self-calibration is performed at 25°C ± 3°C.

Input

Item	Description
Input signal	EFM signal (clock: 4.3218 MHz, 8.6436 MHz, 17.2872 MHz, 34.5744 MHz)
Input signal level	0.4Vp-p to 2Vp-p
Max allowable voltage	4V peak (DC+AC peak)
Input impedance	50Ω±2%, 1MΩ±2% Unbalanced; Switchable
Input terminal	BNC

Jitter Measurement

Item	Read-Out Speed			
	× 1	× 2	× 4	× 8
Measurement range	5.0 to 50.0ns	3.5 to 25.0ns	2.0 to 12.5ns	1.0 to 6.25ns
Resolution	0.1ns	0.1ns *1	0.1ns *2	0.01ns
Accuracy *3	±0.8ns	±0.40ns	±0.20ns	±0.10ns
Effective value conversion time constant (DC-OUT)	100ms	50ms	25ms	12.5ms
Indication interval	1s , 0.1s : Switchable			
Window	22T center, 1T width			
Residual jitter	5.0ns or less	3.5ns or less	2.0ns or less	1.0ns or less

*1: However, equivalent to 0.04ns for resolution of 10ns or less.

*2: However, equivalent to 0.02ns for resolution of 10ns or less.

*3: ± (1.5%FS+0.5digit), modulation frequency 1kHz

JIT Output

Item	Description			
Output signal	Jitter fluctuation waveform			
Output impedance	Approx. 600Ω			
Accuracy	± 10%			
Output terminal	BNC (rear panel)			
Output voltage	Full-scale 3V			
	Unit Conversion	ns/V	mV/ns	× 1, × 2, × 4, × 8 indicate the read-out speed.
	× 1	16.67	60	
	× 2	8.33	120	
	× 4	4.17	240	
× 8	2.08	480		

DC Output

Item	Description			
Output signal	Jitter value*4			
Output impedance	Approx. 600Ω			
Output terminal	BNC			
Accuracy	Within ± 1% of the full scale to the LCD displayed value			
Output voltage	Full-scale 3V			
	Unit Conversion	ns/V	mV/ns	× 1, × 2, × 4, × 8 indicate the read-out speed.
	× 1	16.67	60	
	× 2	8.33	120	
	× 4	4.17	240	
× 8	2.08	480		

*4: Regardless of ⑧TIME CONST switch on the front panel, the time constant of this output signal is set to 100ms, 50ms, 25ms or 12.5ms by ④ SPEED switch.

Supplement:

$$\text{KJM6135(A) measured value} = \text{KJM6235 measured value} (\times 1) \div 3.1 + 0.13$$

RF Output

Item	Description
Output signal	1/10 of input signal
Output impedance	Approx. 50Ω
Output terminal	BNC
Accuracy	Within ± 10% to 1/10 of the input voltage value

General Specifications

Item	Description
Power requirements	
Operating voltage range	100: 90 VAC to 110 VAC Fuse 250 V 1 A (T) 120: 104 VAC to 126 VAC Fuse 250 V 1 A (T) 220: 194 VAC to 236 VAC Fuse 250 V 0.5 A (T) 240: 207 VAC to 250 VAC Fuse 250 V 0.5A (T)
Frequency	50 Hz or 60 Hz
Power consumption	Max. 25W
Mechanical	
Outer dimensions	Case: 200W×80H×270D mm Overall: 215W×90H×300D mm
Weight	Approx. 3kg
Backup battery	Duration: 2 years (from factory shipment) Retention data: Panel switch setting, symmetry level, CAL calibrated value
Insulation resistance	30MΩ or more (500 VDC)
Withstanding voltage	1500 VAC (1 min.)
Environment	
Specified operating temperature range	+5°C to +35°C
Specified operating humidity range	85%RH or less
Storage temperature range	-20°C to +70°C
Storage humidity range	90%RH or less
Accessory	
Power cable	1
Operation manual	1
Fuse	250V 1 A or 250 V 0.5 A ×1

- GPIB Interface (Factory Option)

Panel switch settings and measurement data read-out are possible from the external unit.

The GPIB interface conforms to the ANSI/IEEE Standard 488.1-1987.

Interface Function

Code	Function
SH1	All source hand-shake functions
AH1	All acceptor hand-shake functions
T5	Talker functions (basic output, serial polling, talk-only talker cancel by listener specification)
L4	Listener functions (basic input, listener cancel by talker specification)
SR1	All service request functions
RL0	Remote/local function disabled
PP0	Parallel polling disabled
DC1	All device clear functions
DT0	Device trigger function disabled
C0	Control function disabled
E1	Bus driver = Open collector output

- GPIB Cable

Use the following model name for ordering.

Cable Length	Model Name	Code Name
1 m	408J-101	92080
2 m	408J-102	92070
4 m	408J-104	92090

KIKUSUI ELECTRONICS CORP.

1-1-3, Higashiyamata, Tsuzuki-ku, Yokohama, 224-0023, Japan

Tel : 045-593-7570 Fax : 045-593-7571

KJM 6235

